

(UK2651)

V(0)a



United Kingdom of Great Britain and Northern Ireland

Certificate of EC type-approval of a measuring instrument

Number: UK 2651

issued by the Secretary of State for Trade and Industry
Notified Body Number 0126

In accordance with the requirements of the Non-automatic Weighing Regulations 2000 (SI 2000/3236) which implement, in the United Kingdom, Council Directive 90/384/EEC, this certificate of EC type-approval has been issued to:

**A&D Instruments Ltd
24 Blacklands Way
Abingdon Business Park
Abingdon
Oxfordshire, OX14 1DY
United Kingdom**

in respect of a class II non-automatic weighing instruments designated the A&D GP-XX series.

$n \leq 31,000$ divisions
 $12 \text{ kg} \leq \text{maximum capacity} \leq 101 \text{ kg}$
 $e \geq 1 \text{ g}$
 $d = e/10$
Min = 50d

The necessary data (principal characteristics, alterations, securing, functioning etc) for identification purposes and conditions (when applicable) are set out in the descriptive annex to this certificate.

Signatory: R P Sanders
for Chief Executive
National Weights & Measures Laboratory
Department of Trade and Industry
Stanton Avenue
Teddington
TW11 0JZ
United Kingdom

Date: 27 November 2002
Valid Until: 26 November 2012
Reference No: STD 10753

Descriptive Annex

1 INTRODUCTION

This A&D GP-xx series, are Class II, mains powered, self-indicating non-automatic weighing instruments fitted with a semi-automatic internal self-calibration device and a combined semi-automatic zero setting and semi-automatic subtractive tare balancing device. The “xx” refers to any minor product variation. (Figure 1).

The GP-xx series of instruments that are approved under this type approval certificate are: GP-12K, GP-20K, GP-22K, GP-30K, GP-32K, GP-60K, GP-100K and GP-102K.

2 DESCRIPTION

2.1 Construction

2.1.1 Mechanical

- The metal main unit supports the mechanical unit, internal calibration mass, temperature and position sensor units, relay. The display, switch boards and the main board are located in the display module. The sub platter is mounted on the mechanical unit and four support points protrude through a protective cover. The steel load receptor is mounted on the sub platter support points.
- The integrated display and keyboard unit is mounted on a swinging arm. The unit houses the vacuum fluorescent display, RS232C serial interface port and AC adapter socket. Both the RS232 port and the AC adapter socket are accessible from the right hand side of the display.
- Mains adapter module, model TB-124x, providing a 12VDC output to the weighing instrument display and keyboard unit. The “x” refers to any minor product variation.
- A level indicator is located at the back of the instrument. Four adjustable feet are fitted to the main unit.

2.1.2 This non-automatic weighing instrument may be connected to any compatible point of sale device (POS) if the device has a Test Certificate issued by a Notified Body appointed to certify instruments according to paragraph 1 of annex II of the EC Directive 90/384/EC on non-automatic instruments.

2.2 Position beam lever

The GP-xx weighing instruments work on the principle of “Force Restoration”. Any change in the load on the load receptor causes a position beam lever to pivot on two fulcrum flexures. Attached to this beam is a bobbin, wound with fine wire called the “force coil”, which floats in a permanent magnet, called the “force motor”.

At the end of the position beam lever is a small hole, which allows light from a light-emitting diode to pass through to two photodiodes as it moved up or down. At zero weight, the light detected by the upper photodiode is equal to that detected by the lower photodiode. These three diodes make up the position detector.

When the force coil is pulled up by the leverage exerted from a weight on the load receptor, the position detector detects a change in the position of the force coil as the light reaching the upper photodiode will be greater than the lower one. The balance then feeds the force coil with more voltage to pull it back until the light measured by the two photodiodes is equal. This is achieved by the analogue module receiving photo-current from the photodiodes, converting it into voltage, and boosting it back to the force coil. As the voltage increases, the magnetic power increases, pulling the force coil back until the position detector reads equilibrium.

The current flowing through the force coil generates a voltage proportional to the load on the load receptor. This is read back through the analogue module, this measuring voltage is filtered, then digitised by the A/D converter, the resulting value is counted and fed to the microprocessor.

2.3 Display

The vacuum fluorescent display (VFD) provides a seven digit, 16 mm high seven segment weight display together with a separate field to display the units. A smaller 3 digit seven-segment display is used to display memory data information, number of the data displayed and enunciate total weight values, an additional 11 enunciators can be displayed to indicate, stability, tare, pre-set tare, response time, etc (Figure 2).

The GP-xx series has an auxiliary indicating device where “d” can be displayed as e/10 to Max capacity. The GP-22K, GP-32K and GP-102K instruments have an auxiliary device that will display e/10 for up to 6.1kg (GP-22K and GP-32K) and 61kg (GP-102K).

2.4 Keyboard

The keyboard consists of six functional keys:

- ON:OFF – switches the display on and off, when the display is off the standby indicator is displayed.
- 1/10 SAMPLE – switches the minimum value weighing mode (“d”) on and off and is used to enter the function table mode.
- MODE – switches between the available weighing units and performs a response adjustment and self check.
- CAL – initiates a calibration using the internal mass.
- PRINT – stores data in memory or outputs to the RS232 port and displays the data memory menu.
- 0/T RE-ZERO – sets the display to zero, the key is a combined semi-automatic zero setting and subtractive tare balancing device.

2.5 Operation

2.5.1 Power on

At power on the display goes through a diagnostic test routine that lasts approx. 16 seconds. The display indicates the software version number “P 1.xx”, then “Std”, followed by all seven zeros before showing “test”, which counts down from 9 to 0. After the count down has finished the standby enunciator is illuminated and the internal calibration device is initiated.

The standby enunciator will be illuminated until the ON:OFF button is pressed. A full display test will be performed for approx. two seconds before the instrument captures zero and is ready for use.

2.5.2 Initial zero setting

Initial zero setting device is possible between $\pm 10.0\%$ of max capacity.

2.5.3 Semi-automatic zero setting

Semi-automatic zero setting device is possible between $\pm 2.0\%$ of max capacity.

2.5.4 Combined semi-automatic zero setting and tare balancing device.

Subtractive semi-automatic tare balancing device is provided to the maximum capacity of the instrument.

The subtractive semi-automatic tare balancing and semi-automatic zero functions are operated by the same key, and are controlled by software.

The semi-automatic tare balancing device operates above the $\pm 2.0\%$ threshold of the semi-automatic zero setting device and above the $\pm 10.0\%$ threshold of the initial zero setting device.

2.5.5 Pre-set tare device

A pre-set tare device is provided to the maximum capacity of the instrument.

Up to 20 tare values can be stored in memory and recalled. The enunciator “PT” will be displayed and printed when the pre-set tare function is in use.

2.5.6 Zero tracking

The zero tracking device operates between $\pm 2.0\%$ of maximum capacity, the maximum speed of tracking is 0.5d per second.

2.5.7 Automatic and semi-automatic calibration device using internal mass

When a change in ambient temperature is detected the “standby” indicator will flash and the weighing instrument will automatically initiate a self-calibration using the internal mass.

A semi-automatic self-calibration can be performed by pressing the CAL function key.

A self-calibration will only be performed if the weighing instrument is stable.

2.5.8 Over and under ranging.

Loads greater than nine divisions above the maximum capacity will result in an error “E” being displayed in the centre of the weight display.

2.5.9 Further functions and devices:

- Counting device (pcs)*
- Percentage device (%)*
- Response device (FAST, MID, SLOW)
- Clock and calendar function
- Accumulation device (ttl)
- Comparator device (HI, OK, LO)
- Device for weighing a moving object (indicated by enunciator ANIMAL)
- Memory storage device
- Programming mode*
- Density measurement device (DS)*

*Display of values, which are non-weighing results, are clearly defined by their units and are not for article 1.2(a) applications under the Directive 90/384/EEC.

3 TECHNICAL DATA

3.1 Technical characteristics

3.1.1 Power supply is provided by an A&D mains power adapter, model TB-124x which provides a 12VDC supply to instrument from a 100-240 VAC, 50/60 Hz mains supply.

4 PERIPHERAL DEVICES AND INTERFACES

4.1 Interfaces

The instrument may have the following protected interface:

- 1 off RS232C protected interface.

4.2 Peripheral Devices

Any simple recipient peripheral device may be used if:

- it bears the CE mark of conformity to the EMC Directive 89/336/EEC;
- it is not capable of transmitting any data or instructions into the instrument other than to release a printout or to check for correct data transmission;
- it prints or indicates weighing results and other data as received from the instrument without any modification or further processing; and
- complies with the applicable requirements of EN45501, i.e. 4.2, 4.4, 4.5, 4.6 and 4.7,

5 SOFTWARE

The scale configuration and calibration parameters are stored in EEPROM. The display indicates the software version number at power up in the format of “P 1.xx”.

6 APPROVAL CONDITIONS

This certificate is issued subject to the following conditions:

6.1 Legends

6.1.1 The instrument bears the following legends:

Max
Min
e =
Class II
CE mark
Green M
Verification mark
EC type approval certificate number
Manufactures mark or name
Serial number
Special temperature limits

The CE and verification mark shall be affixed to the instrument and distinctly grouped together. It shall be impossible to remove the CE mark without damaging it. The data plate shall be impossible to remove without it being destroyed.

The markings and inscriptions shall fulfil the requirements of Paragraph 1 of Annex IV of the Directive 90/384/EEC.

6.2 The GP-xx series of instruments are not for use for direct sales to the public.

7 LOCATION OF SEALS AND VERIFICATION MARKS

7.1 The data plate will be mounted on the left side of the weighing instrument in such a manner that it is easily accessible and clearly visible in its regular operating position (Figure 3).

Two wire and lead seals or a tamper evident label prevents access to the display module. Tamper evident stickers are used to prevent access to the sub platter and load cell (Figure 4).

7.2 Components that may not be dismantled or adjusted by the user are secured by a suitable mark or by the use of tamper evident labels. The securing mark may be either:

- a mark of the manufacturer and/or manufacturer's representative, or
- an official mark of a verification officer.

The markings and inscriptions fulfil the requirements of Paragraph 1 of Annex IV of the Directive 90/384/EEC.

8 ILLUSTRATIONS

Figure 1 GP-xx NAWI
Figure 2 VFD display and enunciators
Figure 3 Data plate
Figure 4 Sealing diagrams

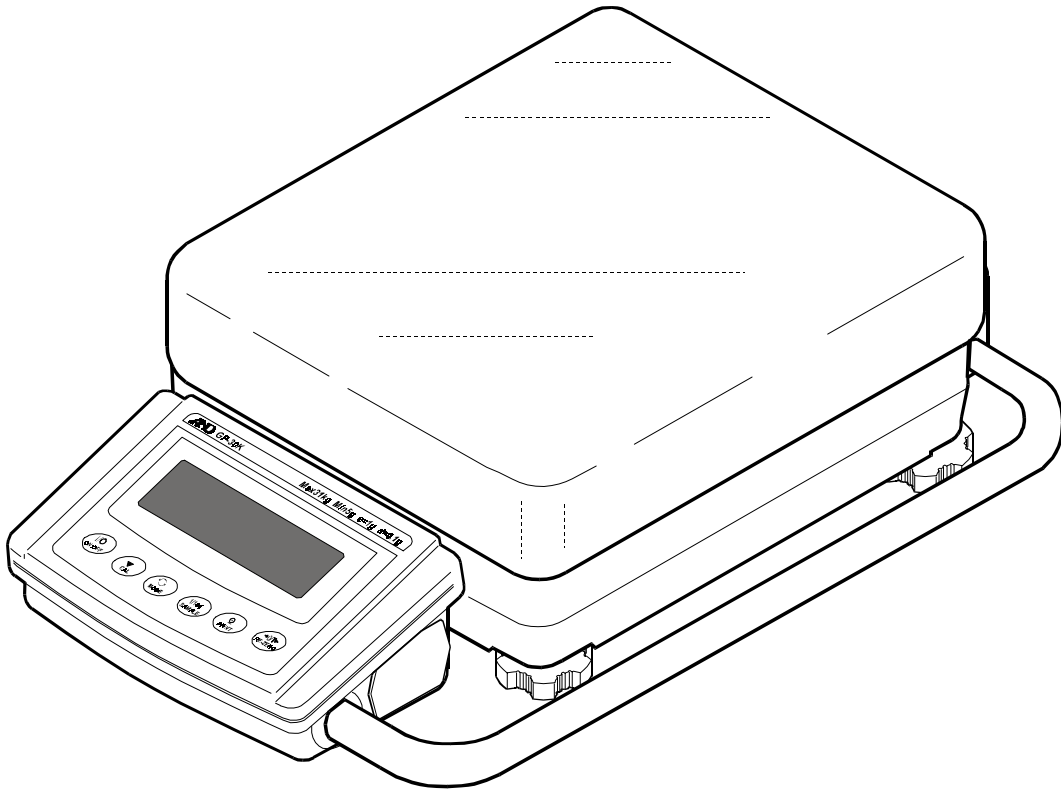

Figure 1 GP-xx NAWI

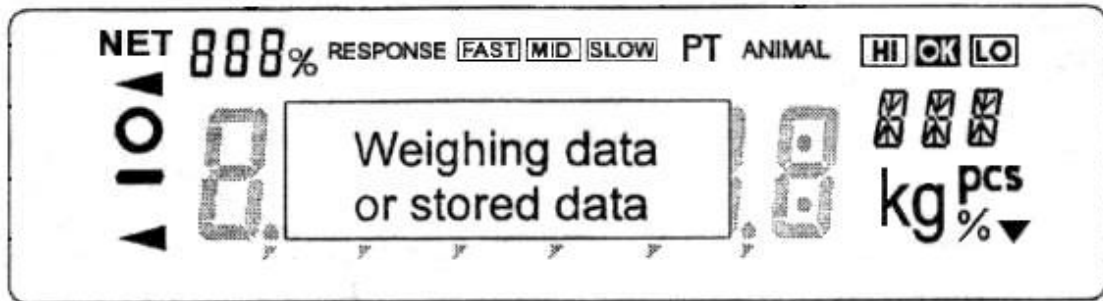

Figure 2 VFD display and enunciators

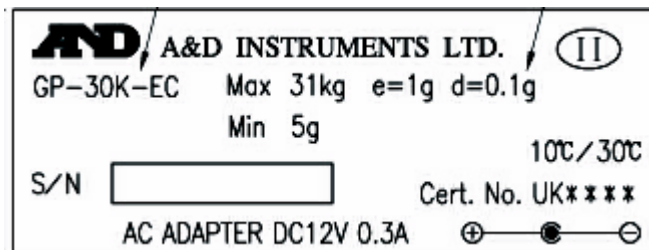

Figure 3 Data plate

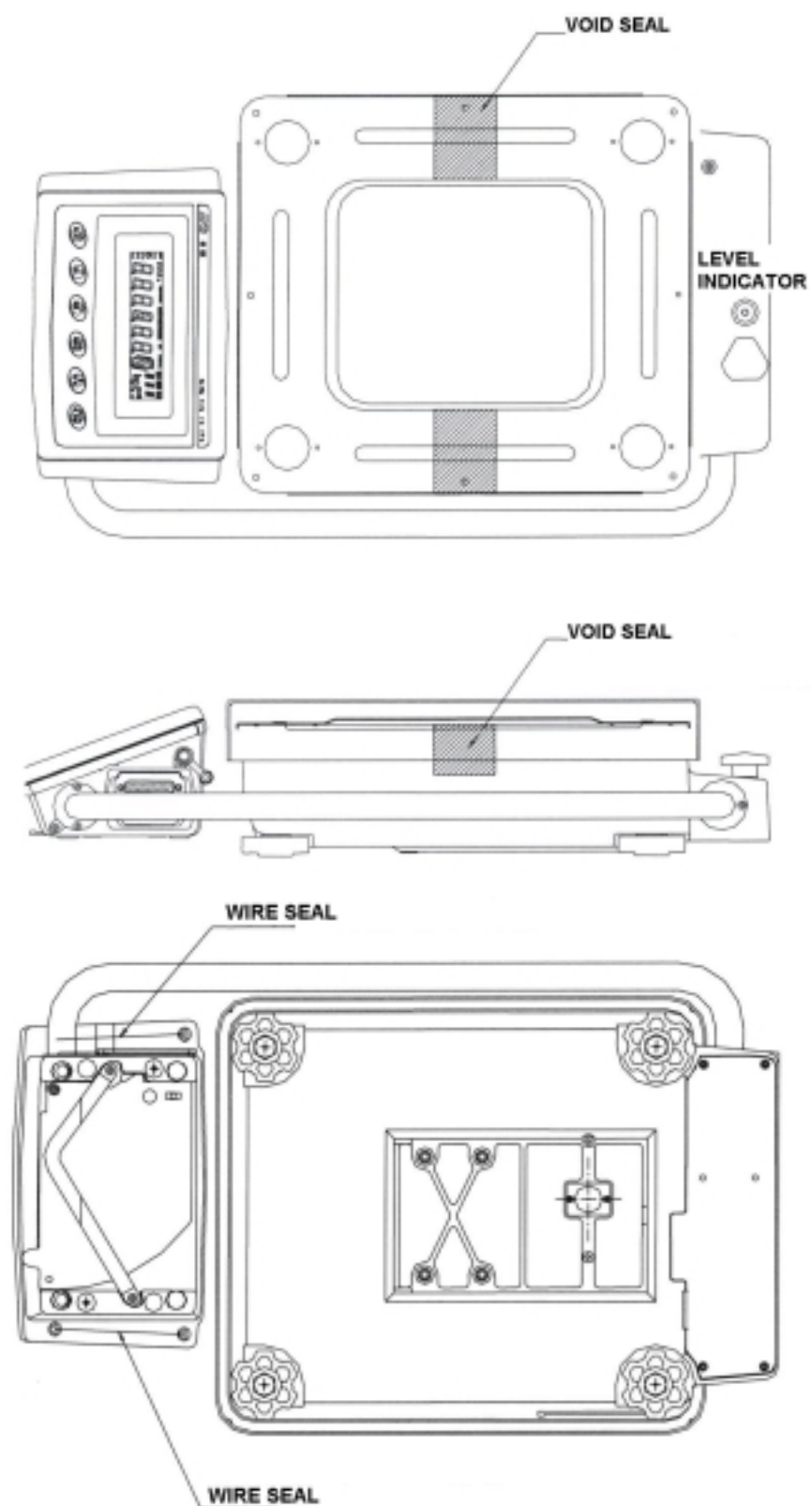

Figure 4 Sealing diagrams

© Crown Copyright 2002.
 This material may be freely reproduced except for sale.