



United Kingdom of Great Britain and Northern Ireland

Certificate of EC type-approval of a measuring instrument

Number: UK 2560

issued by the Secretary of State for Trade and Industry
Notified Body Number 0126

In accordance with the requirements of the Non-automatic Weighing Instruments (EEC Requirements) Regulations 1995 (SI 1995/1907) which implement, in the United Kingdom, Council Directive 90/384/EEC, this certificate of EC type-approval has been issued to:

**A&D Instruments Ltd
The Quadrant
Abingdon Science Park
Abingdon
Oxfordshire
OX14 3YS
United Kingdom**

in respect of a class II non-automatic weighing instrument designated the GX-xx or GF-xx.

$6100 \leq n \leq 61000$ divisions

$210 \text{ g} \leq \text{Max} \leq 8100 \text{ g}$ or $1050 \text{ ct} \leq \text{Max} \leq 40500 \text{ ct}$

$0.01 \text{ g} \leq e \leq 1 \text{ g}$ or $0.1 \text{ ct} \leq e \leq 1 \text{ ct}$

$d = e/10$

$\text{Min} = 20 e$

Authorised alternatives and the necessary data (principal characteristics, alterations, securing, functioning etc) for identification purposes and conditions (when applicable) are set out in the descriptive annex to this certificate.

Signatory:
for

A handwritten signature in blue ink that reads 'R Sanders'.

R P Sanders
Director
National Weights & Measures Laboratory
Department of Trade and Industry
Stanton Avenue
Teddington
Middlesex
TW11 0JZ
United Kingdom

Date: 02 March 2000
Valid Until: 01 March 2010
Reference No: STD 9895

Descriptive Annex

1 NAME AND TYPE OF INSTRUMENT

The A&D GX-xx and GF-xx series of instruments are mains-powered, Class II, non-automatic weighing instruments, fitted with a combined semi-automatic zero setting and subtractive tare balancing device, and a semi-automatic and automatic internal calibration device. The “xx” defines any minor product variation. (see Figure 1)

2 DESCRIPTION

2.1 Construction

2.1.1 Mechanical

Main features:

- 317 mm x 210 mm metal lower-case unit supports the load cell, sensor unit and internal mass. The unit also houses the main board, which incorporates the VFD. The RS232 board and port are mounted at the rear of the unit.
- Keyboard consisting of six function keys.
- Mains power adapter module, model TB-124x, providing a 12 VDC output to the weighing instrument. The “x” defines any minor product variation.

2.1.2 Load cell

The load cell is available in three different capacities:

- Max 610 g, e = 0.01 g
- Max 6100 g, e = 0.1 g
- Max 8100 g, e = 1 g

2.1.3 Keyboard

The keyboard consists of six functional keys (see Figure 1):

- ON/OFF - switches the display on and off, when the display is turned off the standby indicator is displayed.
- SAMPLE - switches the minimum weighing value (“d”) on and off and is used to enter into the function table mode.
- MODE - switches between the available weighing units and performs response adjustment and self-check.
- CAL - performs a calibration using the internal mass.
- PRINT - stores the weighing data in memory or outputs to the RS232 and displays the data memory menu.
- RE-ZERO - sets the display to zero. The re-zero key is a combined semi-automatic zero setting subtractive tare-balancing device.

2.1.4 Display

The VFD provides a 1.1 cm high, 7 segment field to display the weight value, and an additional field to display the units.

Up to 9 enunciators can be displayed, to indicate stability of equilibrium, self-calibration, processing, capacity, response time, etc.

2.1.5 Circuitry

All signal processing and communications with the load cell and the I/O are achieved from the control circuitry within the main unit. The A-D PCB is shielded for EMC compliance.

2.2 Operation

2.2.1 Switch on

On power up the instrument performs internal diagnostic tests, and a full display test, after which the unit will activate the internal self-calibration mechanism to check and if necessary reset the position of the internal calibration mass and then attempt to capture zero. If faults are detected an error message is displayed.

2.2.2 Semi-Automatic zero setting

Automatic and semi-automatic zero setting is possible between $\pm 2.0\%$ of max capacity. Operation of the semi-automatic zero within this range will cancel any current tare operations.

2.2.3 Initial zero setting

Initial zero setting is possible between $\pm 10\%$ of max capacity.

2.2.4 Zero tracking

Zero tracking operates between $\pm 2.0\%$ of maximum capacity. The maximum speed of tracking is 0.5 d per second.

2.2.5 Combined semi-automatic zero-setting and subtractive tare balancing device.

Subtractive semi-automatic tare balancing facility is provided to the maximum capacity of the instrument.

The subtractive tare and the semi-automatic zero devices are operated by the same function key, and are controlled by software.

The subtractive tare facility operates above the 2% of max capacity threshold, of the semi-automatic zero setting device and above the 10% of max capacity threshold, of the initial zero setting device.

2.2.6 Automatic and semi-automatic calibration device using internal mass

A flashing enunciator in the bottom left of the display indicates a change in the ambient temperature. The weighing instrument will then perform an automatic self-calibration.

A semi-automatic self-calibration can be performed by pressing the CAL function key.

2.2.7 Over range

Loads greater than nine divisions above maximum capacity result in an error code shown as “E” in the centre of the weight display. The stability enunciator is blanked for unstable loads.

2.2.8 Further functions and devices

- Device for weighing unstable samples (indicated by enunciator ANIMAL)
- Memory storage device
- Time and date device (GX-xx only)
- Density determination device (DS)*
- Percentage device (Pct)*
- Counting device (PC)*
- Newton device (N)*
- Custom unit device (MLt)*
- Selection of non-weighing units (OZ, Lb, LOz, OZt, dwt, GN)*

*Display of values, which are non-weighing results, are clearly identified by their units, and are not for article 1.2(a) applications under the Directive.

3 TECHNICAL DATA

3.1 Technical characteristics

3.1.1 Power supply 100 - 240 V ac 50/60 Hz providing a 12 V dc supply to the instrument.

4 PERIPHERAL DEVICES AND INTERFACES

4.1 Peripheral devices

Any simple recipient peripheral device may be used if:

- it bears the CE mark for conformity to the EMC Directive 89/336/EEC;
- it is not capable of transmitting any data or instructions into the NAWI other than to release a printout or check for correct data transmission; and
- it prints or indicates weighing results and other data as received from the NAWI without any modification or further processing; and
- complies with the application requirements of BS EN45501 ie sections 4.2, 4.4, 4.5, 4.6 and 4.7.

4.2 Interfaces

1 off RS232 bi-directional protected interface

5 APPROVAL CONDITIONS

5.1 Legends

5.1.1 The instrument bears the following legends (see Figure 2):

Max
Min
e =
d=
Class II
10 °C to 30 °C

6 LOCATION OF SEALS AND VERIFICATION MARKS

The data plate and the green M sticker are mounted on the right hand side of the instrument (see Figure 2).

A wire and lead seal prevents the removal of a metal plate on the back panel of the instrument, which in turn prevents access to the calibration lock on the RS232 board (see Figure 3).

The wire and lead seal may have the mark of a verification officer, or alternatively, the manufacturers mark.

7 ALTERNATIVES

7.1 Having the GF-xx, which is metrologically identical to the GX-xx, but having components related to the memory and clock functions removed.

8 ILLUSTRATIONS

Figure 1 General View

Figure 2 Location of data plate

Figure 3 Sealing diagram

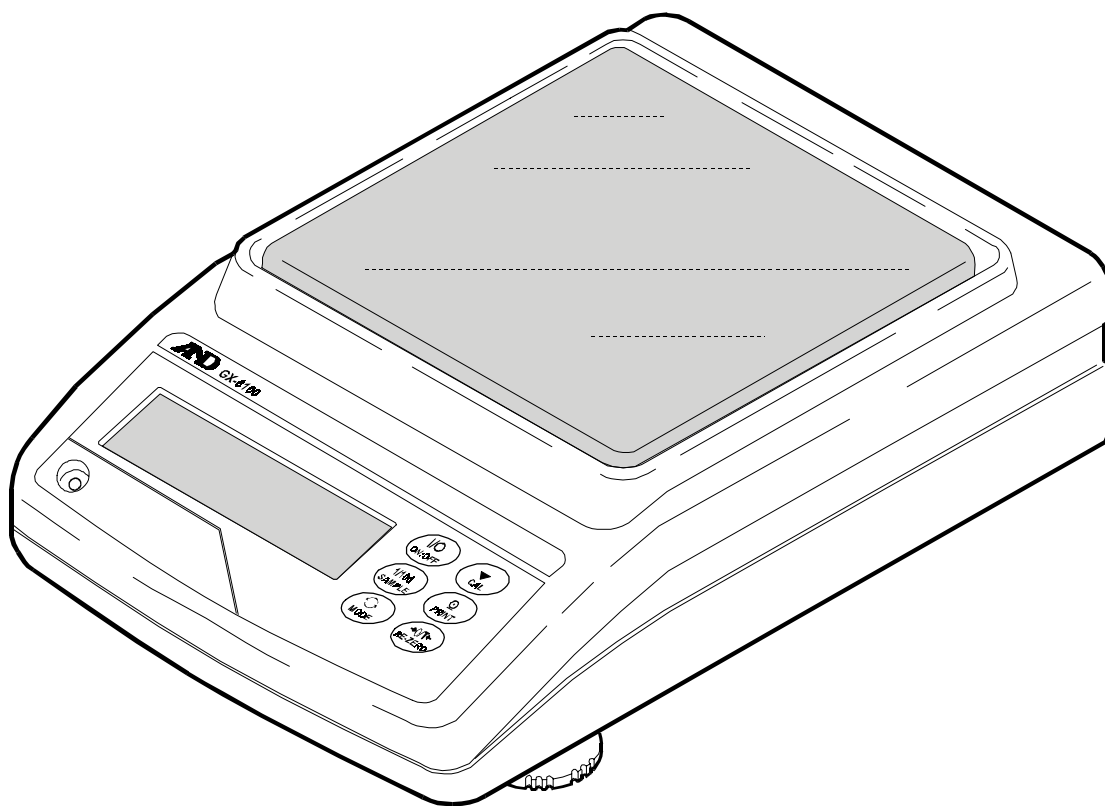

Figure 1 General View.

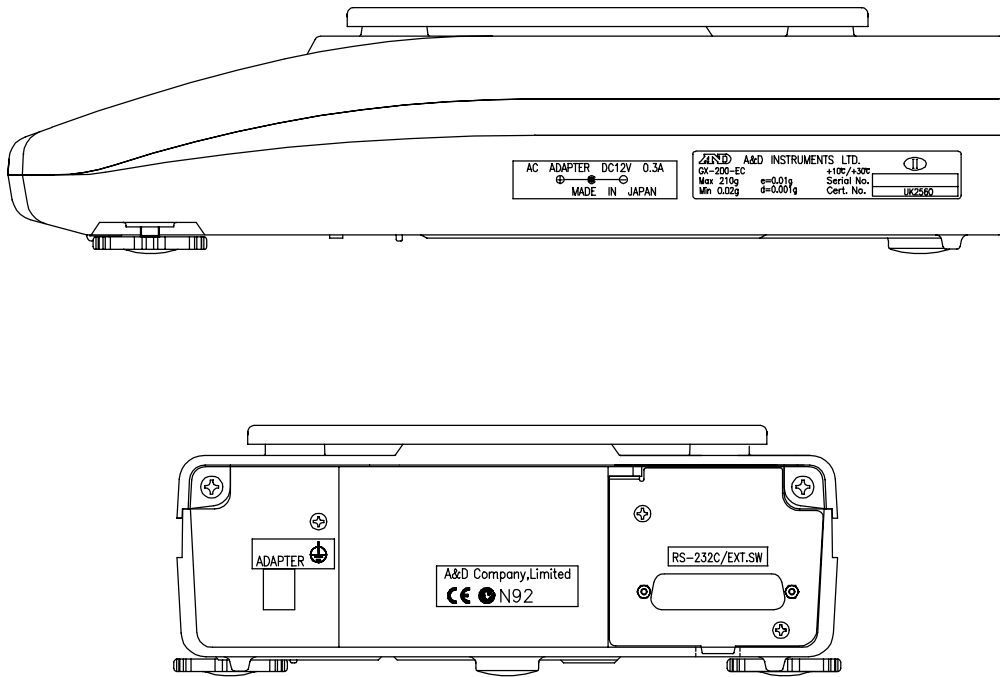

Figure 2 Location of data plate and CE marking

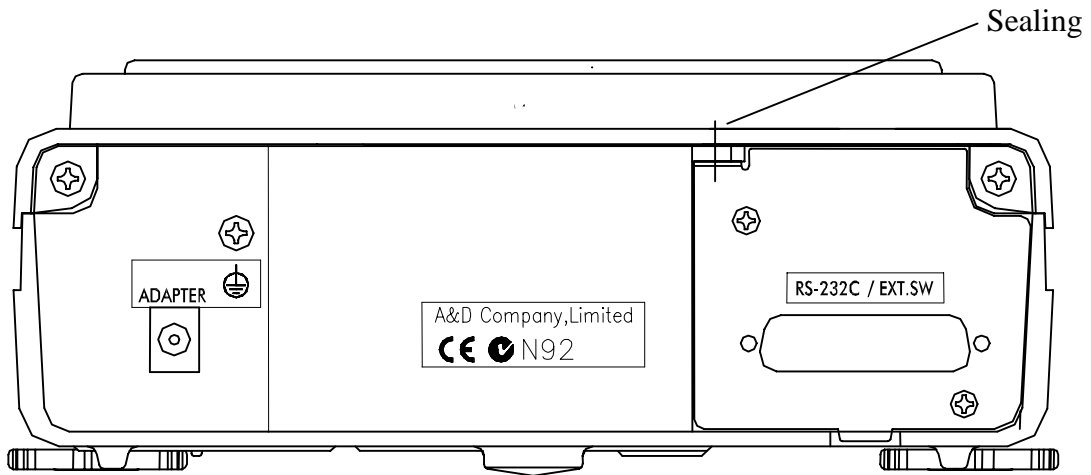

Figure 3 Sealing diagram

© Crown Copyright 2000
 This material may be freely reproduced except for sale.