



United Kingdom of Great Britain and Northern Ireland

## Certificate of EC type-approval of a measuring instrument

### Number: UK 2549 Revision 1

issued by the Secretary of State for Trade and Industry  
Notified Body Number 0126

In accordance with the requirements of the Non-automatic Weighing Instruments (EEC Requirements) Regulations 1995 (SI 1995/1905) which implement, in the United Kingdom, Council Directive 90/384/EEC, this certificate of EC type-approval has been issued to:

**A&D Instruments Ltd.**  
**24-26 Blacklands Way**  
**Abingdon Business Park**  
**Abingdon**  
**OX14 1DY**

in respect of a class III non-automatic weighing instrument designated the HV-15KGL.

Max <sub>1</sub>	3.0 kg	Max <sub>2</sub>	6.0 kg	Max <sub>3</sub>	15.0 kg
Min <sub>1</sub>	20 g	Min <sub>2</sub>	40 g	Min <sub>3</sub>	100 g
e <sub>1</sub>	1 g	e <sub>2</sub>	2 g	e <sub>3</sub>	5 g

The necessary data (principal characteristics, alterations, securing, functioning etc) for identification purposes and conditions (when applicable) are set out in the descriptive annex to this certificate.

This revision replaces previous versions of the certificate.

Signatory:  
for

P R Dixon  
Director  
National Weights & Measures Laboratory  
Department of Trade and Industry  
Stanton Avenue  
Teddington  
Middlesex  
TW11 0JZ  
United Kingdom

Date: 28 November 2005  
Valid Until: 17 November 2009  
Reference No: T1128/0037

# Descriptive Annex

## 1 NAME AND TYPE OF INSTRUMENT

The A&D HV-15KGL is a mains powered, Class III, non-automatic, triple range with automatic changeover or triple range, weighing instrument. Its maximum capacity is 15 kg (see Figure 1).

## 2 DESCRIPTION

### 2.1 Construction

#### 2.1.1 Mechanical

Main features:

- A metal base enclosure supports the load cell. The base and load cell are environmentally sealed and protected against water and dust.
- Keyboard and built in display. Consisting of a large weight display and functional keys.
- A CE-marked mains power adapter, providing an 8-9 VDC output to the weighing instrument.

#### 2.1.2 Keyboard

The keyboard and display are housed in an ABS module. The module is separate to the weighing base.

The display is a seven segment LCD, which provides a 12.5cm x 5cm display area, the display characters are 25mm high.

The current weighing range is indicated on the display together with other enunciators to indicate units of weight, net, pre-set tare, zero, stability, comparator indication, low battery, etc.

The keyboard consists of a membrane keypad.

#### 2.1.3 Digital circuitry

All signal processing and communications with the load cell and the I/O's are achieved from the control circuitry within the display/keyboard unit.

## **2.2 Operation**

Main features:

- On power up the instrument performs an internal diagnostic test, after which the unit will attempt to set zero. If faults are detected an error message is displayed.
- Automatic and semi-automatic zero setting is possible between +/-2.0% of maximum capacity. Operation of the semi-automatic zero will cancel any current tare operations.
- Automatic zero tracking operates between +/-2.0% of maximum capacity. The maximum speed of tracking is 0.5d per second.
- Subtractive semi-automatic and pre-set tare facilities are provided.

Loads greater than nine divisions above maximum capacity, result in an error code shown as "E". The stability symbol is blanked for unstable loads.

Any simple recipient printer may be used if:

- bears the CE mark for conformity to the EMC Directive 89/336/EEC;
- is not capable of transmitting any data or instructions into the POS other than for releasing the printout or checking for correct data transmission;
- prints weighing results and other data as received from the terminal without any modification or further processing; and
- complies with the application requirements of BS EN45501 ie sections 4.2, 4.4, 4.5, 4.6 and 4.7.

## **3 TECHNICAL DATA**

### **3.1 Technical characteristics**

**3.1.1** Power supply 100 - 240 V ac, 50/60 Hz. Or an 8-9 V dc supply from either an AC/DC adapter or internal batteries.

## **4 INTERFACES**

- RS232 interface / relay output / buzzer
- RS422/485 interface with relay o/p

## 5 APPROVAL CONDITIONS

### 5.1 Legends

5.1.1 The instrument bears the following legends:

Max  
Min  
e =  
Class III

## 6 LOCATION OF SEALS AND VERIFICATION MARKS

Wire and lead seals prevent access to the calibration switch. The seals are fitted through a fixed plastic post and a drilled retaining screw (Figure 2).

Verification marks and the CE markings are located on or adjacent to the data plate.

## 7 ALTERNATIVES

7.1 Having an alternative vacuum florescent display (HV-15KGV) (Figure 1).

7.2 Having the following alternative capacities: (Figure 3)

HV-60KGL/KGV:	Max <sub>1</sub>	15 kg	Max <sub>2</sub>	30 kg	Max <sub>3</sub>	60 kg
	Min <sub>1</sub>	100 g	Min <sub>2</sub>	200 g	Min <sub>3</sub>	400 g
	e <sub>1</sub> =	5 g	e <sub>2</sub> =	10 g	e <sub>3</sub> =	20 g
HV-200KGL/KGV:	Max <sub>1</sub>	60 kg	Max <sub>2</sub>	150 kg	Max <sub>3</sub>	220 kg
	Min <sub>1</sub>	400 g	Min <sub>2</sub>	1 kg	Min <sub>3</sub>	2 kg
	e <sub>1</sub> =	20 g	e <sub>2</sub> =	50 g	e <sub>3</sub> =	100 g

7.3 Having an alternative roller conveyor load receptor (Figure 4).

7.4 Having the HV-WP, which is the same as the HV-G, but is environmentally sealed and has a stainless steel load receptor as shown in Figure 5.

## 8 ILLUSTRATIONS

- Figure 1 General view HV-15KGL/KGV
- Figure 2 Sealing diagram
- Figure 3 General view HV-60KGL/KGV and HV-200KGL/KGV model
- Figure 4 Conveyor load receptor.
- Figure 5 General view HV-WP

**CERTIFICATE HISTORY**

ISSUE NO.	DATE	DESCRIPTION
UK2549	18 November 1999	Type approval first issued
UK2549 Revision 1	28 November 2005	Revision 1 issued. Change to section 2.1.1 to permit any CE-marked mains adaptor to be used. Change of address. Consolidation of Additions 1 & 2.

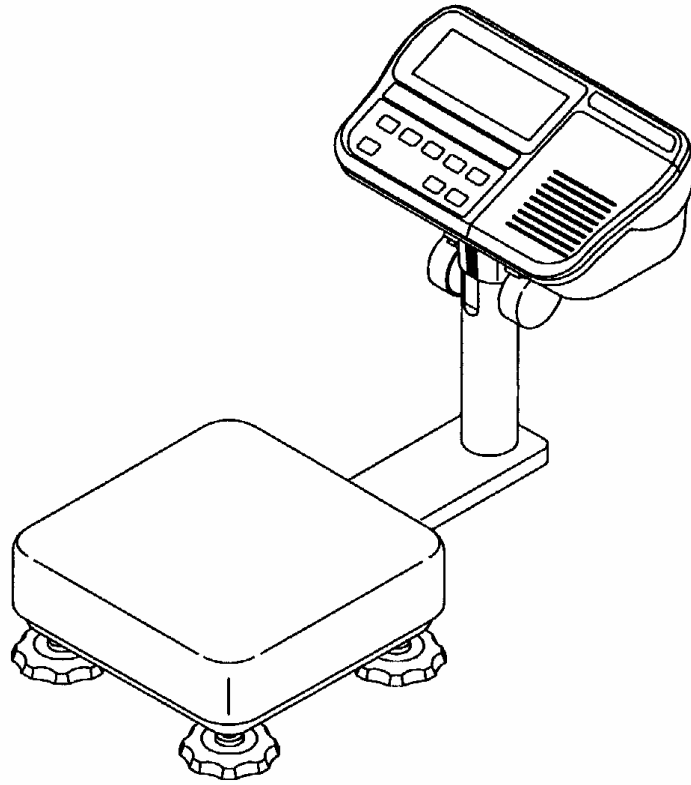

**Figure 1 General view HV-15KGL/KGV**

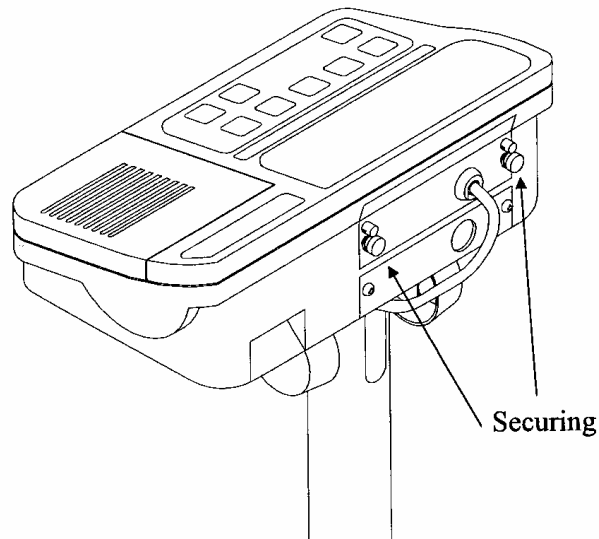

**Figure 2 Sealing diagram**

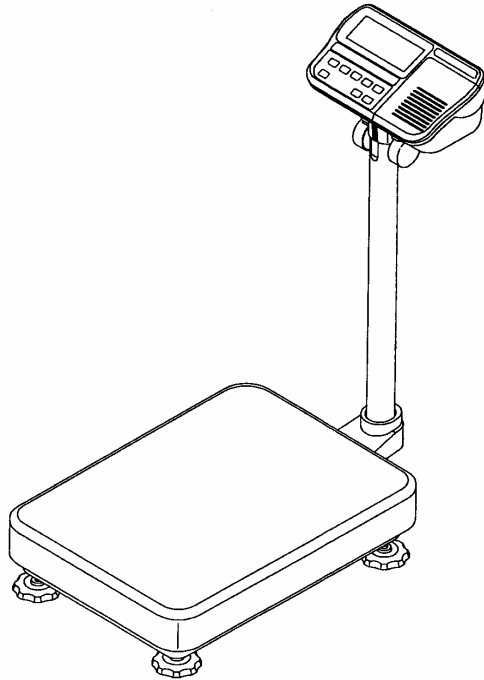

**Figure 3**      **General view HV-60KGL/KGV and HV-200KGL/KGV model**

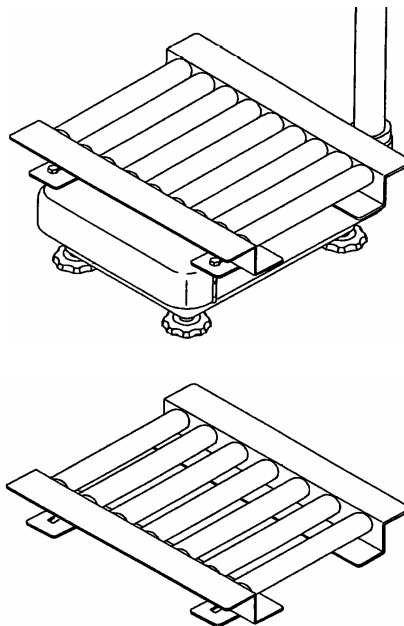

**Figure 4**      **Conveyor load receptor**

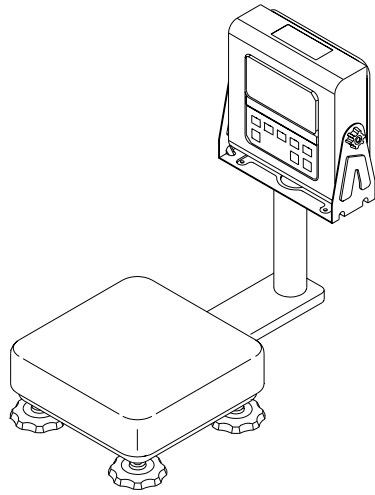

**Figure 5 General view HV-WP**